

# Development of nutation motors (improvement of pneumatic nutation motor by optimizing diaphragm design)<sup>†</sup>

Shinji ODA<sup>1</sup>, Koichi SUZUMORI<sup>1,\*</sup>, Kazuo UZUKA<sup>2</sup> and Isao ENOMOTO<sup>2</sup>

<sup>1</sup>Okayama Univ., 3-1-1, Tsushima-naka, Kita-ku, Okayama, Japan

<sup>2</sup>TOK BEARING Co. LTD., 21-4, 2-Chome, Azusawa, Itabashi-Ku, Tokyo, Japan

(Manuscript Received May 1, 2009; Revised October 23, 2009; Accepted October 30, 2009)

## Abstract

This article describes the improvement of a pneumatic nutation motor. Pneumatic nutation motors that are driven by diaphragm are expected to have bigger torque. In this report, refined design of the diaphragm is discussed. First, several different shapes of diaphragms are proposed and analyzed with nonlinear FEM. Second, a “bellows type” diaphragm is fabricated and built in the motor. Holding fixture for the diaphragm is also refined to improve its performance. Finally, torques of the new model and conventional model are compared, resulting in that the new model generates the torque 20 percent higher than that of the conventional model at any air pressure.

**Keywords:** Actuator; Pneumatic actuator; Stepping motor; Bevel gear; Diaphragm

## 1. Introduction

The pneumatic nutation motor has been developed as a low-speed and high torque motor with stepping motion [1]. Fig. 1 shows the general relative motions of a pair of cone- and cup-shaped objects, A and B, which roll over each other without slipping. This relative motion between two objects is called “nutation” in which one object tilts and rotates to the other. Nutation motor utilizes this motion to realize high torque.

Fig. 2 shows a typical configuration of the pneumatic nutation motor. As shown, a pneumatic nutation motor consists of some numbers, typically three, of small pneumatic actuators, a reduction mechanism, and an output shaft. The reduction mechanism consists of a pair of bevel gears,  $G_1$  and  $G_2$ , which have an unequal number of teeth and engage each other. The gears  $G_1$  and  $G_2$  correspond to the objects A and B in Fig. 1, respectively.

By driving the small pneumatic actuators sequentially, they act on the back surface of the bevel gear  $G_2$ , as shown in Fig. 2, resulting in the nutation of gear  $G_2$ . Because the gears  $G_1$  and  $G_2$  engage each other and their numbers of teeth are different, one of the bevel gears has to rotate.

There can be many other variations of design of the bevel gear configuration and pneumatic actuator configuration for the nutation motors [2], but the motor torque always owes to

the force that pneumatic actuator pushes bevel gear  $G_2$  [3]. In this report, to increase the motor torque, the pneumatic actuator configuration is discussed.

## 2. Optimum design of diaphragm

Fig. 3 shows the FN1-type pneumatic nutation motor, which means the fixed gear  $G_1$  and nutation gear  $G_2$  are expected to need small number of components and be suitable for miniaturization [2].

A new shape of diaphragm named “bellows type” is invented. Several different shapes of diaphragms are proposed and analyzed with nonlinear FEM. Figs. 4(a) to (e) show the cross-sections of the models that are used for FEM analysis. Type A is the conventional model which has vertical sidewall and fillet geometry. Type B is the corn model which has pinched-top shape. Type C also means the corn model which

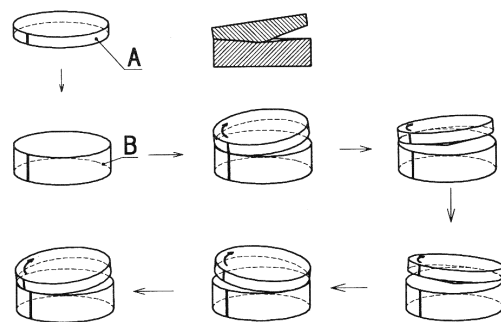

Fig. 1. Working principle of nutation.

<sup>†</sup> This paper was presented at the ICMDT 2009, Jeju, Korea, June 2009. This paper was recommended for publication in revised form by Guest Editors Sung-Lim Ko, Keiichi Watanuki.

\*Corresponding author. Tel.: +81 86 251 8159, Fax.: +81 86 251 8159  
 E-mail address: suzumori@sys.okayama-u.ac.jp

Table 1. Analytical results.

	Type A	Type B	Type C	Type D	Type E
Maximum contact force [MPa]	0.074	0.072	0.113	0.130	0.155
Maximum friction force [MPa]	0.015	0.014	0.017	0.055	0.015
Maximum Mises stress [MPa]	1.534	1.182	1.594	3.778	1.702

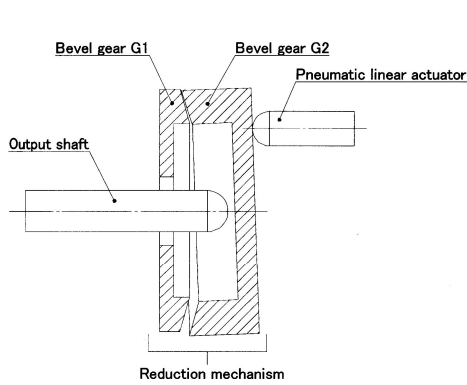

Fig. 2. Working principle of a pneumatic nutation motor.

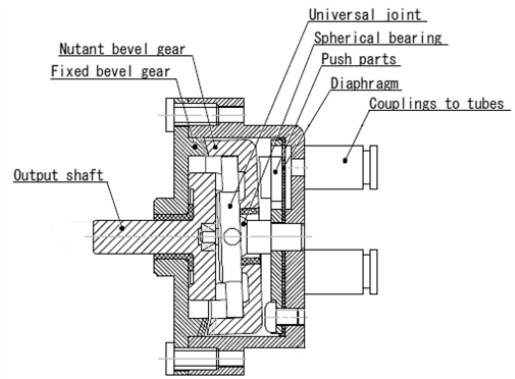

Fig. 3. Structure of pneumatic motor FN1-type.

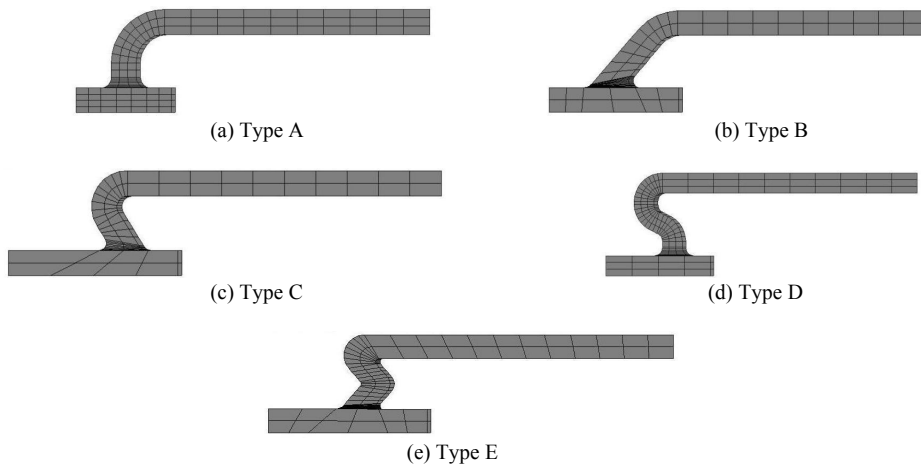

Fig. 4. Analyzed models of diaphragms; the cross-section of FEM models.

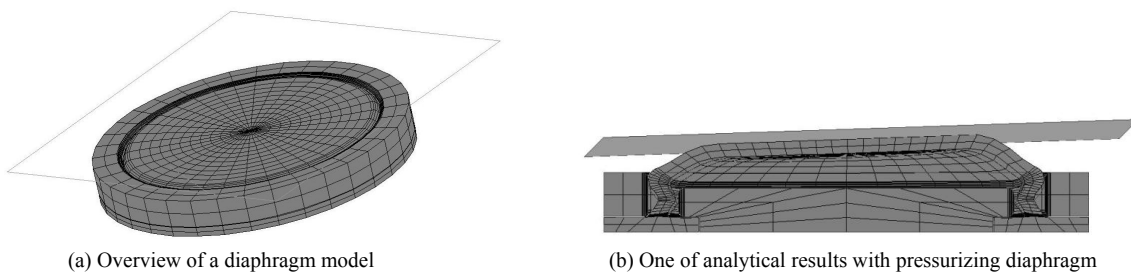

Fig. 5. An example of nonlinear FEM analysis.

has broad-top shape. Type D is the bellows model which has bellows at the sidewall. Type E also means the bellows model which has bellows that are finer than those of type D. Each diaphragm is analyzed, as shown in Fig. 5.

Five models of diaphragms shown in Fig.4 are analyzed and

evaluated. Each diaphragm is evaluated with contact force that the diaphragm generates to push the bevel gear  $G_2$ , and the friction force between the diaphragm and the bevel gear  $G_2$ . Each diaphragm is evaluated with 1/3 model because the diaphragm for FN-1 type has 1/3 symmetry.

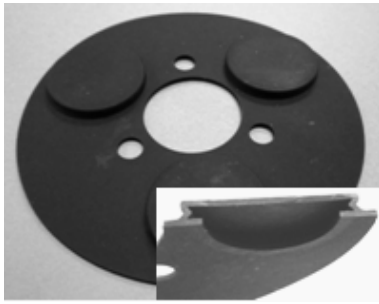

Fig. 6. Fabricated bellows type diaphragm (type E).

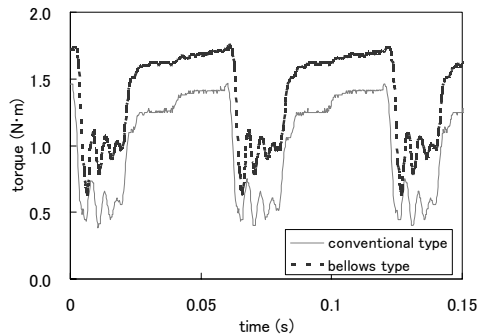

Fig. 7. Comparison of maximum torque between the conventional type [3] and the bellows type at 5 [rpm], with full-pitch drive.

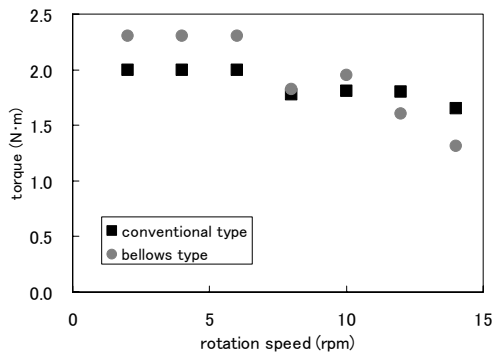

Fig. 8. Comparison of maximum torque between conventional type and bellows type for rotation speed, with half-pitch drive.

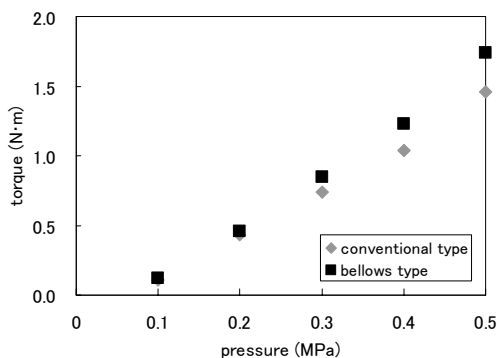

Fig. 9. Comparison of response between conventional type and bellows type.

Table 1 shows the analytical results. The contact force is the most important because the motor torque is mainly generated by this force. As the best shape of the diaphragm, Type E is selected through these analyses. The durability of each diaphragm can be evaluated with friction force and Mises stress to find that the shape of diaphragm is not crucial. The friction force and the Mises stress of Type E that may cause fracturing of the diaphragm are almost same as those of Type A. Type A is termed the “conventional type” and type E the “bellows type.” Fig. 6 shows the fabricated bellows type diaphragm and its cross-section.

### 3. Experiment

The bellows type diaphragm is built in the motor, and compared with conventional type. The FN-1 type motor in which the diaphragm is built has 40 [mm] radius. Fig. 7 shows the comparison of the maximum torque between the conventional type and the bellows type with full-pitch drive [2]. The rotation speed of this experiment is made at 5 [rpm] because pneumatic nutation motors are developed for low-speed drive and positioning operations. The results show that the bellows type model generates the torque 20 percent higher than that of conventional model at any air pressure. On the other hand, Fig. 8 shows the comparison of the maximum torque between the conventional type and the bellows type at each rotation speed, where 0.5 [MPa] air pressure is applied on the diaphragm with half-pitch drive [2]. The bellows type model shows bigger torque while it drives at low rotation speed with each driving principle. In addition, the response speed is found to be almost as fast as that of the conventional type, as shown in Fig. 9.

Based on these experimental results, it is concluded that the bellows type diaphragm is suitable for pneumatic nutation motor at low-speed drive. To improve the torque in high-speed, optimizing pressure control can be applied [3].

### 4. Conclusion

Several shapes of diaphragms have been proposed and analyzed with nonlinear FEM. By optimizing diaphragm design, the bellows type is fabricated. This diaphragm is built in an FN-1 type pneumatic nutation motor and compared with the conventional type about motor torque and response speed. With these experimental results, the bellows type increases the maximum motor torque. This design can be applied to all types of nutation motors which use diaphragm as a pneumatic actuator.

### References

- [1] K. Uzuka, I. Enomoto and K. Suzumori, Development of nutation motors (1<sup>st</sup> report, driving principle and basic characteristics of pneumatic nutation motor), *Transactions of the Japan Society of Mechanical Engineers*, 72 (716) (2006) 1194–1199.

- [2] K. Uzuka, I. Enomoto and K. Suzumori, Comparative assessment of several nutation motor types, *IEEE/ASME Transactions on MECHATRONICS*, 14 (1) (2009) 82-91.
- [3] S. Oda, K. Uzuka, I. Enomoto and K. Suzumori, Development of nutation motors (8<sup>th</sup> report, improvement of pneumatic nutation motor by optimizing pressure control), Collected papers at *The 8<sup>th</sup> Machine Design and Tribology Division Meeting in JSME*, (2008) 131-134.



**Shinji ODA** received his B.S. in System Engineering from Okayama University, Japan, in 2008. He has been in Graduate School of Natural Science and Technology, Okayama University working on his M.S. degree.



**Koichi SUZUMORI** received his B.S., M.S., and Ph.D. degrees from Yokohama National University, Japan, in 1982, 1984, and 1990, respectively, all in Mechanical Engineering.

He is currently a Professor in the Graduate School of Natural Science and Technology, Okayama University. His

research interests include actuators, sensors, microrobots, and electropneumatic devices.



**Kazuo UZUKA** received his B.S., and M.S. degrees in Mechanical Engineering from Chiba Institute of Technology, Chiba, Japan, in 1995 and 1997, and Ph.D. degree from Okayama University, in 2009, respectively. Since 1997, he has been with TOK Bearing Company, Ltd., Tokyo, Japan, where he is currently

a Leader in the Development Section.



**Isao ENOMOTO** received his B.S. degree in engineering from the Chiba University, Chiba, Japan, in 1971. He was an Engineer with TOK Bearing Company, Ltd., Tokyo, Japan.